

Model: Model K-P1		Date: 07-Apr-01	No.: MG058001
Modified Article: Parts Catalog Corrections		Prepared by: K. Misugi	
From: Technical Services Dept., GTS Division			
Reason for Modification:	<input checked="" type="checkbox"/> Parts catalog correction <input type="checkbox"/> To facilitate assembly <input type="checkbox"/> Part standardization	<input type="checkbox"/> Vendor change <input type="checkbox"/> To improve reliability <input checked="" type="checkbox"/> Other	<input type="checkbox"/> To meet standards ()

Please note the following Parts Catalog corrections and component modifications applied to improve reliability:

Parts Catalog Corrections:

Old part number	New part number	Description	Q'ty	Int	Page	Index	Note
G0523272	G0563271	Bypass Front Cover - RIC - Europe/Asia	1		3	18	1
---	G0522789	Shield - Polygon Scanner	1		5	25	2
G0523620	G0523644	Transfer Roller Guide	1		13	2	3
G0523615	G0523619	Gear - Transfer Roller	1		13	4	
G0523614	G0523618	Positioning Roller - Transfer	1		13	5	
G0523294	G0523307	Transport Guide Mylar	1		13	11	
	G0523625	Right Bushing - Transfer	1		13	29	3
G0524617	G0524647	Heater Terminal	1		17	15	
	11050267	Harness Clamp - YMC-10-0 (Correction on the index number.)	1		23	112→113	4
	11050516	Clamp (Correction on the index number.)	1		23	111→114	
	11050310	Harness Clamp - LWS - 1S	1		25	114	5
	04513008B	Tapping Screw - M3x8	1		25	115	
	09504006B	Screw - M4x6	1		25	116	
	04514006H	Tapping Screw - M4x6	1		25	117	

Notes:

- 1: Only for Europe and Asia models. Aficio logo is on the bypass front cover.
- 2 - 5: See the illustrations on the following pages.

Modified Parts:

Old part number	New part number	Description	Q'ty	Int	Page	Index	Note
G0521562	G0521566	Front Cover	1	X/O	3	14	
	G0523140	Magnetic Clutch Assembly	1	O/O	7	23	6
AX200211		Magnetic Clutch - Z56	1		7	4	
G0523117		Clutch Balancer - Right	1		7	19	
G0523116		Clutch Balancer - Left	1		7	20	
04513006B		Tapping Screw - M3x6	1		7	103	
G0521122		Magnetic Clutch Holder	1		21	3	
04503010B		Tapping Screw - M3x10	1		21	102	
G0523106	G0523128	Bushing - Paper Feed Roller	1		X/O	7	
G0524645	G0524644	Upper Fusing Entrance Guide	1	X/O	17	9	
G0521216	G0521218	Engine Board Cover	1	O/O	23	20	

Notes:

- 6: See the illustration on the last page.

Model: Model K-P1	Date: 07-Apr-01	No.: MG058001
-------------------	-----------------	---------------

Note 2: Parts Catalog, page 4 - Index No. 25

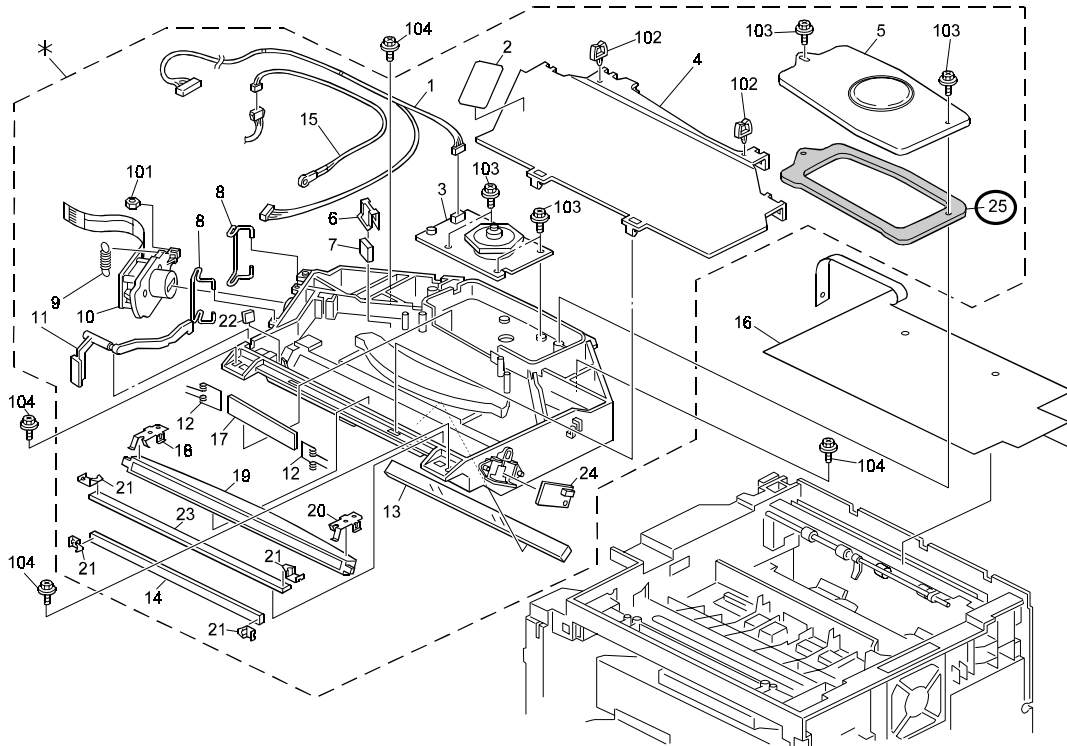

Note 3: Parts Catalog, page 12 - Index No. 2, 29

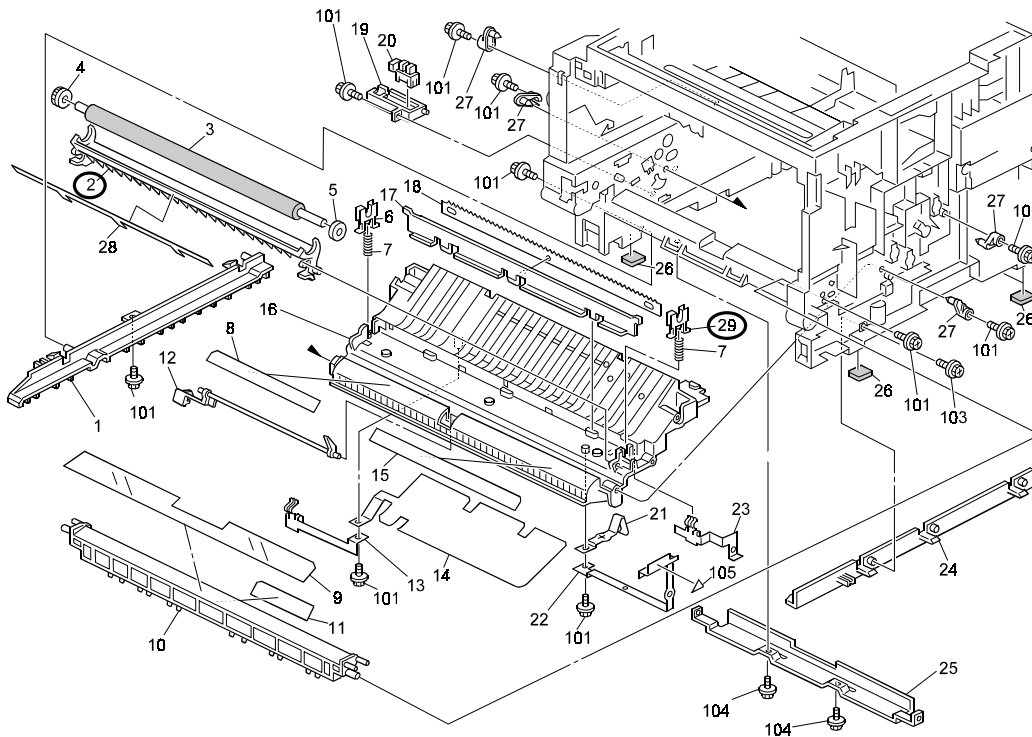

Model: Model K-P1	Date: 07-Apr-01	No.: MG058001
-------------------	-----------------	---------------

Note 4: Parts Catalog, page 22 - Index No. 113, 114

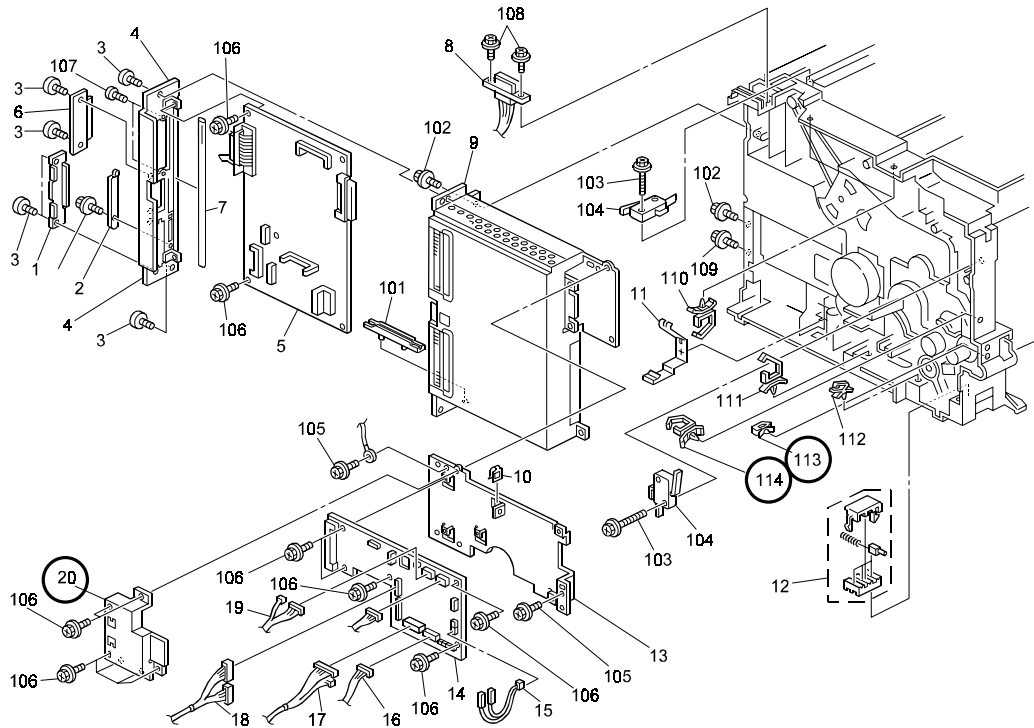

Note 5: Parts Catalog page 24 - Index No. 114, 115, 116, 117

The inlet (index no. 19 in the illustration) is described on page 10 in the parts catalog.

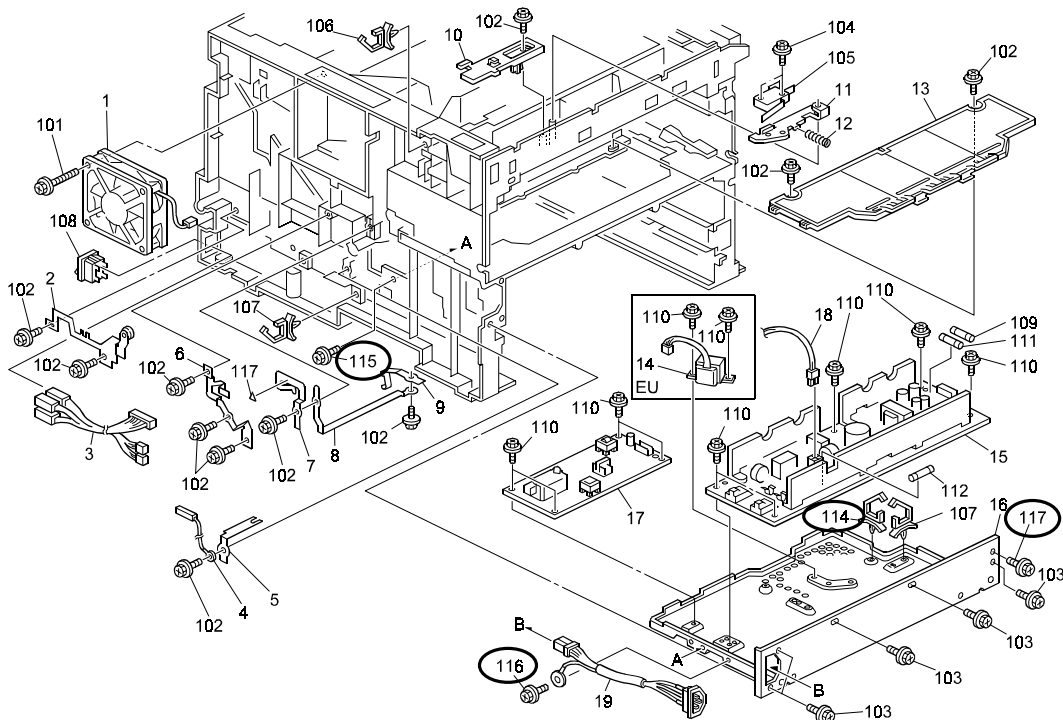

Model: Model K-P1	Date: 07-Apr-01	No.: MG058001
-------------------	-----------------	---------------

Note 6: Parts Catalog page 6 - Index No. 23

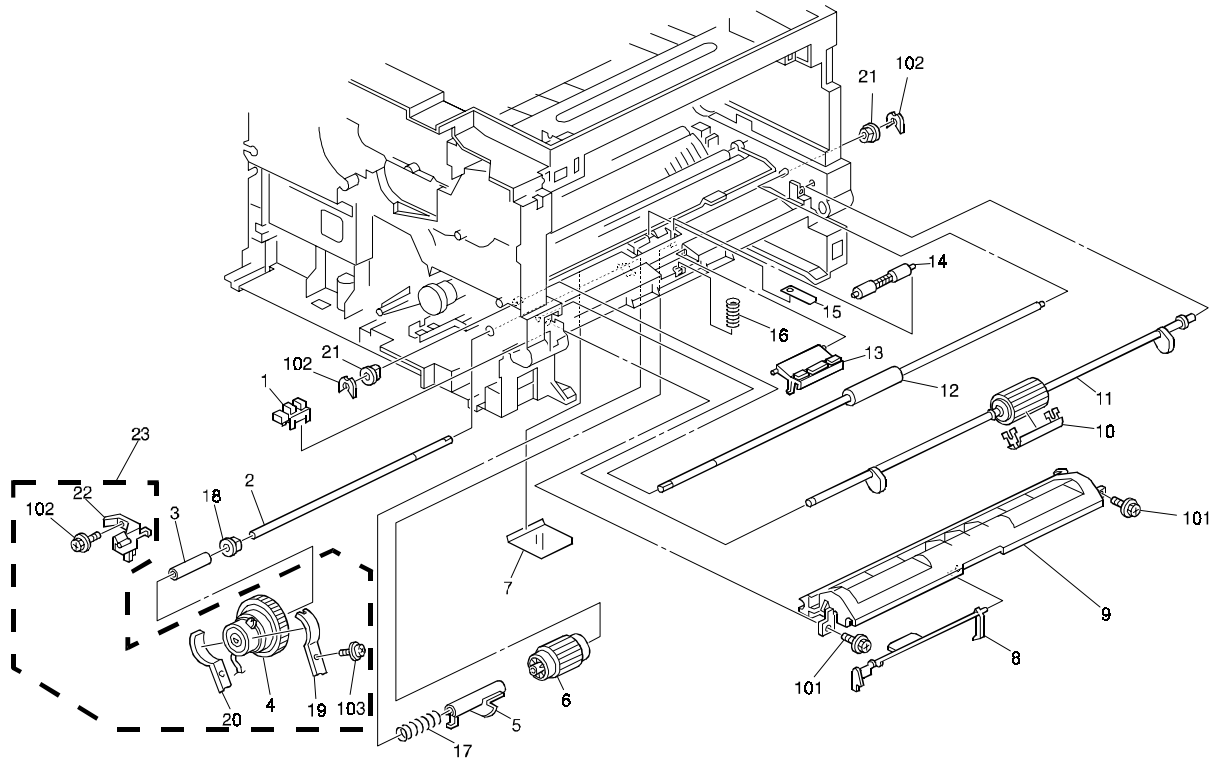

Model: Model K-P1		Date: 16-Jul-01	No.: MG058002
Modified Article: Paper Tray Rear Cover		Prepared by: K. Misugi	
From: Technical Services Dept., GTS Division			
Reason for Modification:	<input checked="" type="checkbox"/> Parts catalog correction	<input type="checkbox"/> Vendor change	<input type="checkbox"/> To meet standards ()
	<input type="checkbox"/> To facilitate assembly	<input type="checkbox"/> To improve reliability	
	<input type="checkbox"/> Part standardization	<input checked="" type="checkbox"/> Other	

The following item is now available as a service part.

Old part number	New part number	Description	Q'ty	Int	Page	Index	Note
	G0523111	Paper Tray Rear Cover	1				

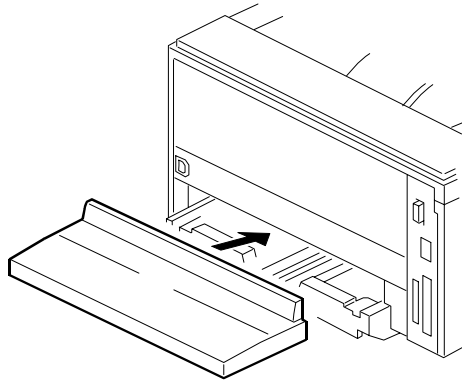

The rear cover has been registered as a service part for customers using paper sizes larger than A4 SEF, since some may want a cover for the portion of the tray that sticks out on the rear side of the machine.

To install, hook the 2 inserts onto the projections on the rear side of the machine. The cover is about 376 x 165 x 63 mm and can cover the tray up to its maximum extension (A3).

Model: Model K-P1 China		Date: 2-Aug-02	No.: MG058003
Modified Article: Power Cord - 230V		Prepared by: A. Ishiyama	
From: Technical Services sec. Service Planning Dept.			
Reason for Modification:	<input type="checkbox"/> Parts catalog correction	<input checked="" type="checkbox"/> Vendor change	<input type="checkbox"/> To meet standards ()
	<input type="checkbox"/> To facilitate assembly	<input type="checkbox"/> To improve reliability	
	<input type="checkbox"/> Part standardization	<input type="checkbox"/> Other	

The Power Cord has been changed due to a vendor change (China model only, G056-69 and G058-69).

Old part number	New part number	Description	Q'ty	Int	Page	Index	Note
GZ000004	GZ000005	Power Cord – 230V	1	O/O	11	18	

Model: Model K-P1		Date: 6-Sep-02	No.: MG058004
Modified Article: Paper Exit Cover		Prepared by: A. Ishiyama	
From: Technical Services sec. Service Planning Dept.			
Reason for Modification:	<input type="checkbox"/> Parts catalog correction <input type="checkbox"/> To facilitate assembly <input type="checkbox"/> Part standardization	<input type="checkbox"/> Vendor change <input checked="" type="checkbox"/> To improve reliability <input type="checkbox"/> Other	<input type="checkbox"/> To meet standards ()
Modification Schedule:	From April 2002 production run		

The Paper Exit Cover has been modified to ensure that it does not open during printing, which can happen if the cover is not closed correctly.

Note: This applies to all models: K-P1:G056/G058.

Old part number	New part number	Description	Q'ty	Int	Page	Index	Note
G0521505	G0521512	Paper Exit Cover	1	X/O	3	35	

Model: Model K-P1		Date: 25-Jun-03	No.: MG058005
Modified Article: NIB Option (G573)		Prepared by: A. Ishiyama	
From: 1st Technical Support Sec. Service Support Dept.			
Reason for Modification:	<input type="checkbox"/> Parts catalog correction	<input type="checkbox"/> Vendor change	<input type="checkbox"/> To meet standards ()
	<input type="checkbox"/> To facilitate assembly	<input type="checkbox"/> To improve reliability	
	<input type="checkbox"/> Part standardization	<input checked="" type="checkbox"/> Other	

Due to discontinuation of the NIB option (G573) for the model K-P1, each component contained in the option has been individually registered as service parts.

Note: This applies only to the G056 model.

Old part number	New part number	Description	Q'ty	Int	Page	Index	Note
	G0585700L	PCB: GWPHY	0→1	-		1	
	G0585900	Spacer – 9 mm	0→1			2	
	G0586001A	Panel: GWPHY	0→1			3	
	16071242	Ferrite Core – NF100	0→1			4	
	04513006B	Tapping Screw – M3x6	0→2			101	

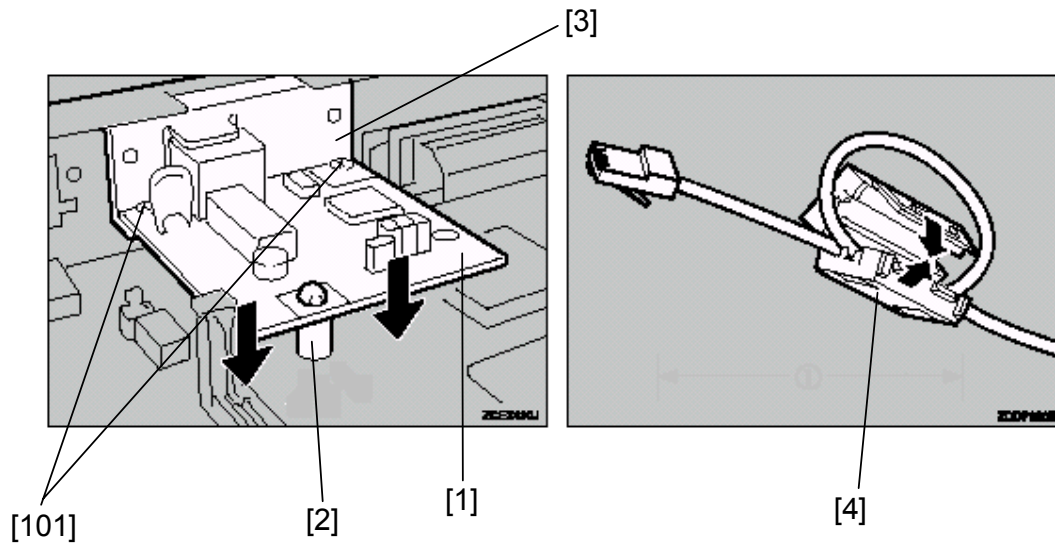

Reissued: 2-Oct-03

Model: Model K-P1	Date: 26-Sep-03	No.: MG058006a
-------------------	-----------------	----------------

MB Correction

The items in bold italics have been corrected or added.

Modified Article: Base - Manual Feed : adhesion		Prepared by: T.Shintani	
From: 1st Technical Support Sec. Service Support Dept.			
Reason for Modification:	<input type="checkbox"/> Parts catalog correction	<input type="checkbox"/> Vendor change	<input type="checkbox"/> To meet standards ()
	<input type="checkbox"/> To facilitate assembly	<input checked="" type="checkbox"/> To improve reliability	
	<input type="checkbox"/> Part standardization	<input type="checkbox"/> Other	
Modification Schedule:	From September 2002 production		

Base - Manual Feed (Bypass Tray) in the K-P3 has been modified to prevent paper feed noise during developing. The same change was also applied to these products: K-P1/K-P2.

Note: This applies to all models: K-P2, G073/G074 as well as K-P1, G056/G058.

Old part number	New part number	Description	Q'ty	Int	Page	Index	Note
G0523273B	G0763273	Base - Manual Feed : Adhesion	1→1	X/O	3	25	1
	G0763281	Supporting Plate:Base:ManualFE	0→1		3	40	1
	G0763282	Supporting Plate:Base:ManualFE	0→1		3	41	1
	G04503008B 04503008B	Tapping Screw – M3×8	0→1		3	101	1

Note1: The above parts should be replaced together as a set.

Reissued: 2-Oct-03

Model: Model K-P1

Date: 26-Sep-03

No.: MG058006a

1.EXTERIOR (G056/G058)

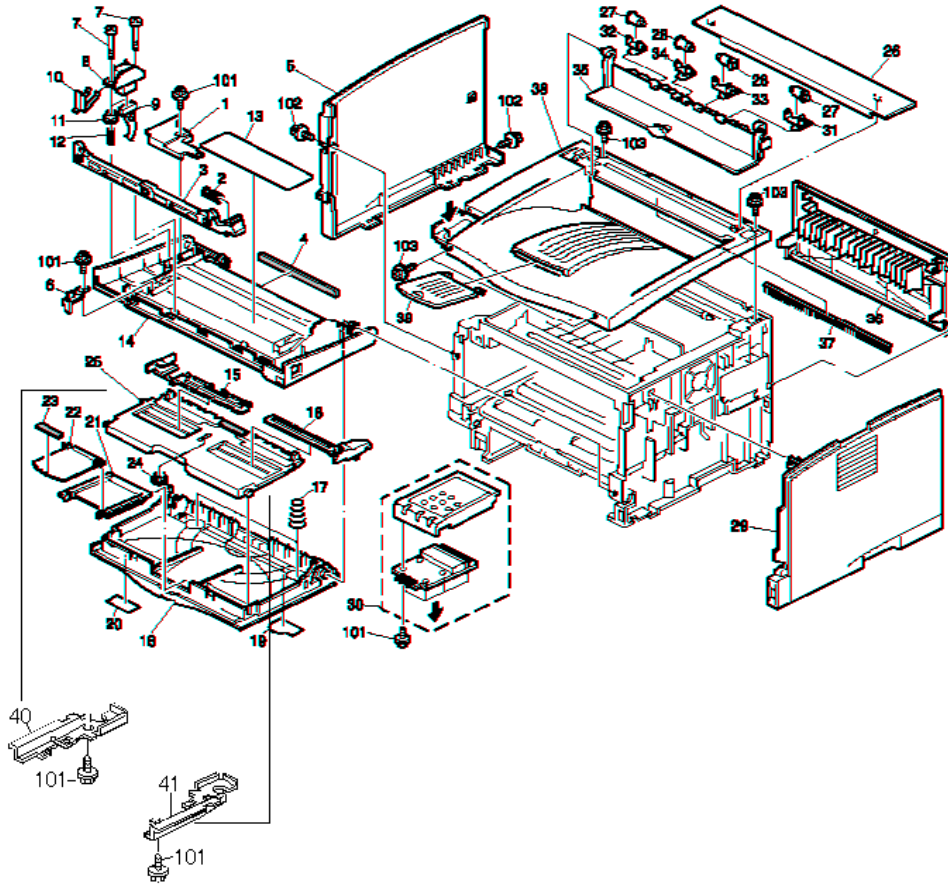

Model: Model K-P1		Date: 26-Sep-03	No.: MG058007
Modified Article: Separation Pad - Bypass		Prepared by: T.Shintani	
From: 1st Technical Support Sec. Service Support Dept.			
Reason for Modification:	<input type="checkbox"/> Parts catalog correction <input type="checkbox"/> To facilitate assembly <input type="checkbox"/> Part standardization	<input type="checkbox"/> Vendor change <input checked="" type="checkbox"/> To improve reliability <input type="checkbox"/> Other	<input type="checkbox"/> To meet standards ()
Modification Schedule:	From October 2002 production		

Separation Pad - Bypass has been modified. When using special paper in the Japanese market, paper does not pass correctly and the tip part of the paper bends.

Note: This applies to all models: K-P1, G056/G058 as well as K-P2, G073/G074.

Old part number	New part number	Description	Q'ty	Int	Page	Index	Note
G0523290F	G0763290	Separation Pad - Bypass	1→1	X/O	7	13	

Model: Model K-P1		Date: 26-Sep-03	No.: MG058008
Modified Article: Paper Tray		Prepared by: T.Shintani	
From: 1st Technical Support Sec. Service Support Dept.			
Reason for Modification:	<input type="checkbox"/> Parts catalog correction <input type="checkbox"/> To facilitate assembly <input type="checkbox"/> Part standardization	<input type="checkbox"/> Vendor change <input type="checkbox"/> To improve reliability <input checked="" type="checkbox"/> Other	<input type="checkbox"/> To meet standards ()
Modification Schedule:	This item is now available as a service part.		

Additional ditches have been applied for the special Chinese paper size. This applies to all models: K-P1:G056/G058.

Old part number	New part number	Description	Q'ty	Int	Page	Index	Note
	G0523046	Paper Tray Ass'y – EUR/Asia	0→1		15	*	1.2
G0523051	G0523061	Paper Tray - Front	1→1	X/O	15	15	2
G0523052	G0523062	Paper Tray - Rear	1→1	X/O	15	7	2

Notes:

1. The part number for complete assembly of the paper tray has been newly registered.
2. The above parts should be replaced together as a set.

Model: Model K-P1		Date: 26-Sep-03	No.: MG058009
Modified Article: Specification change against China models		Prepared by: T.Shintani	
From: 1st Technical Support Sec. Service Support Dept.			
Reason for Modification:	<input type="checkbox"/> Parts catalog correction <input type="checkbox"/> To facilitate assembly <input checked="" type="checkbox"/> Part standardization	<input type="checkbox"/> Vendor change <input checked="" type="checkbox"/> To improve reliability <input type="checkbox"/> Other	<input type="checkbox"/> To meet standards ()
Modification Schedule:	From October 2003 production for china models. (These changes are available only for service parts on other models.)		

Old part number	New part number	Description	Q'ty	Int	Page	Index	Note
G0521522	G0751652	Upper Cover – EUR/Asia	1→1	X/O	3	38	1
G0521565	G0751650	Right Cover	1→1	X/O	3	29	1
	G0751651	Louver	0→1		3	42	1
G0523046	G0763049	Paper Tray Ass'y – EUR/Asia	1→1	X/O	15	*	2
G0523061	G0763061	Paper Tray - Front	1→1	X/O	15	15	2
	G0763063	Grip - Paper Tray Ass'y	0→1		15	19	2
	04503008B	Tapping Screw - M3x8	0→1		15	101	2
	G0523111	Paper Tray Rear Cover	0→1		11	28	3
G0521103	G0881103	Gear – PCU	1→1	X/O	21	18	4

Notes:

1. The upper cover has been changed due to parts standardization with K-P2. The above parts should be replaced together as a set. Please refer to illustration #1.
2. These changes come from the addition of the paper tray grip. These changes are the same as for K-P2. Please refer to MG073006 for details as well as illustration #2.
3. Added to the accessory to cover the rear part of the tray to protect paper from paper dust accumulation. Please refer to MG058002 for details
4. This modification uses the same part and material as for the K-P3.

Model: Model K-P1	Date: 26-Sep-03	No.: MG058009
-------------------	-----------------	---------------

[Drawing 1]

Exterior for K-P1

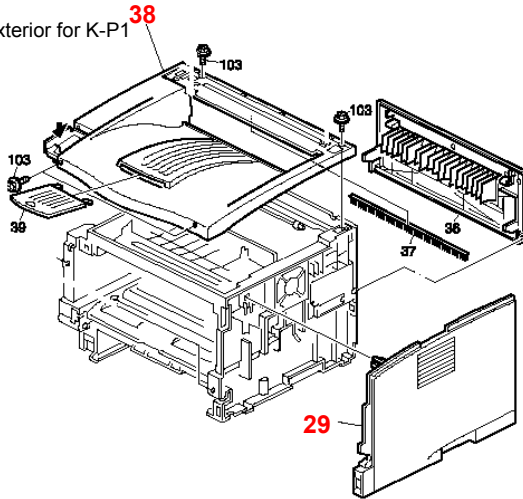

Exterior for K-P2

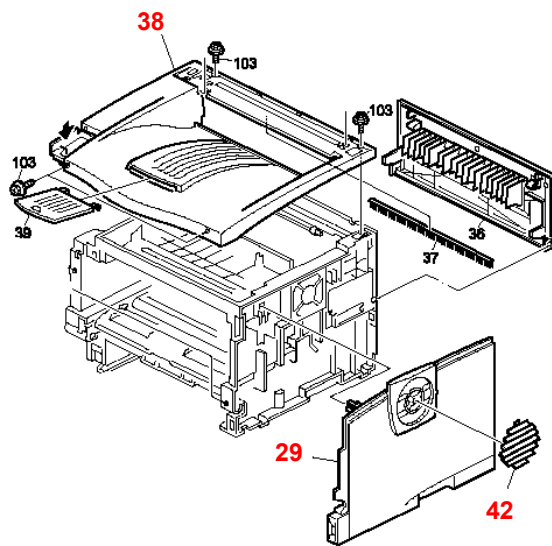

[Drawing 2]

7.CASSETTE (G056/G058)

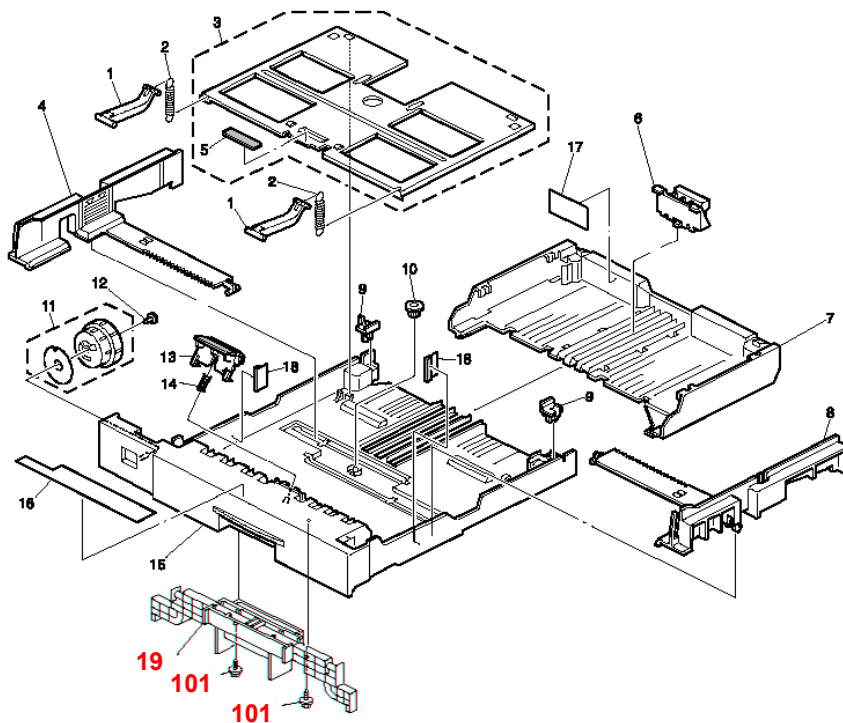

Model: Model K- P1		Date: 1-Jun-04	No.: MG058010
Modified Article: Discharge Brush at paper exit		Prepared by: A. Ishiyama	
From: 1st Technical Support Sec. Service Support Dept.			
Reason for Modification:	<input type="checkbox"/> Parts catalog correction <input type="checkbox"/> To facilitate assembly <input type="checkbox"/> Part standardization	<input type="checkbox"/> Vendor change <input checked="" type="checkbox"/> To improve reliability <input type="checkbox"/> Other	<input type="checkbox"/> To meet standards ()
Modification Schedule:	The new part is available at SPC.		

The following has been modified to further improve charge removal performance, especially for print jobs made in duplex mode or under low-humidity conditions.

Note: The new part is common to Model K-P3 (G091).

Old Part Number	New Part Number	Description	Q'ty	Int	Page	Index	Note
G0524885		Discharge Brush – Paper Exit	1→0	X/O	3	37	
	G0524889	Discharge Brush: Exit: Ass'y	0→1				

Model: Model K- P1	Date: 21-Dec-04	No.: MG058011
--------------------	-----------------	---------------

Modified Article: Transfer Roller Gear		Prepared by: A. Ishiyama	
From: 1st Technical Support Sec. Service Support Dept.			
Reason for Modification:	<input type="checkbox"/> Parts catalog correction <input type="checkbox"/> To facilitate assembly <input checked="" type="checkbox"/> Part standardization	<input type="checkbox"/> Vendor change <input type="checkbox"/> To improve reliability <input type="checkbox"/> Other	<input type="checkbox"/> To meet standards ()
Modification Schedule:	The new part is available at SPC.		

Old Part Number	New Part Number	Description	Q'ty	Int	Page	Index	Note
G0523619	G0763619	Transfer Roller Gear	1→1	O/O	13	4	

Change/Reason: Parts standardization with the next model (Model K-P2/P3).

Model: Model K- P1		Date: 20-Jan-05	No.: MG058012
Modified Article: Stay – Paper Feed		Prepared by: A. Ishiyama	
From: 1st Technical Support Sec. Service Support Dept.			
Reason for Modification:	<input type="checkbox"/> Parts catalog correction <input type="checkbox"/> To facilitate assembly <input checked="" type="checkbox"/> Part standardization	<input type="checkbox"/> Vendor change <input type="checkbox"/> To improve reliability <input type="checkbox"/> Other	<input type="checkbox"/> To meet standards ()
Modification Schedule:	From January '05 production		

Old Part Number	New Part Number	Description	Q'ty	Int	Page	Index	Note
G0523100	G1112571	Stay – Paper Feed	1→1	X/O	9	7	

Change/Reason: Parts standardization with the next model (Model K-P4).

Model: Model K- P1		Date: 20-Jan-05	No.: MG058013
Modified Article: Power Cord – 230V		Prepared by: A. Ishiyama	
From: 1st Technical Support Sec. Service Support Dept.			
Reason for Modification:	<input type="checkbox"/> Parts catalog correction <input type="checkbox"/> To facilitate assembly <input checked="" type="checkbox"/> Part standardization	<input type="checkbox"/> Vendor change <input type="checkbox"/> To improve reliability <input type="checkbox"/> Other	<input type="checkbox"/> To meet standards ()
Modification Schedule:	From January '05 production		

Old Part Number	New Part Number	Description	Q'ty	Int	Page	Index	Note
GZ000003	G1025502	Power Cord – 230V	1→1	O/O	11	18	

Change/Reason: Parts standardization with the next model (Model K-P4).

Note: This applies only to the EU models (230V).

Model: Model K- P1		Date: 7-Apr-05	No.: MG058014
Modified Article: Transfer Roller		Prepared by: A. Ishiyama	
From: 1st Technical Support Sec. Service Support Dept.			
Reason for Modification:	<input type="checkbox"/> Parts catalog correction <input type="checkbox"/> To facilitate assembly <input checked="" type="checkbox"/> Part standardization	<input type="checkbox"/> Vendor change <input type="checkbox"/> To improve reliability <input type="checkbox"/> Other	<input type="checkbox"/> To meet standards ()
Modification Schedule:	From January '05 production		

Old Part Number	New Part Number	Description	Q'ty	Int	Page	Index	Note
G0523616	G1116256	Transfer Roller	1→1	X/O	13	3	
G0523618	G1296251	Positioning Roller - Transfer	1→1	X/O	13	5	
G0763619	G1296252	Gear - Transfer Roller	1→1	X/O	13	4	
	G1296255	Bushing	0→2	-	13	30	

Change/Reason: Parts standardization with the next model (Model K-P4).

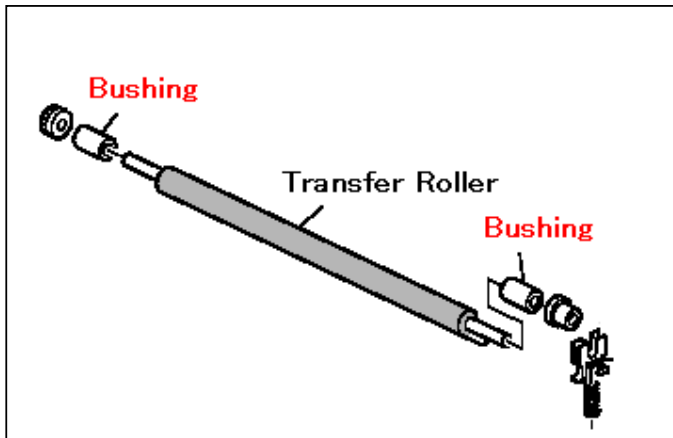

Model: Model K- P1		Date: 25-Mar-05	No.: MG058015
Modified Article: Environmental Correspondances		Prepared by: A. Ishiyama	
From: 1st Technical Support Sec. Service Support Dept.			
Reason for Modification:	<input type="checkbox"/> Parts catalog correction <input type="checkbox"/> To facilitate assembly <input checked="" type="checkbox"/> Part standardization	<input type="checkbox"/> Vendor change <input type="checkbox"/> To improve reliability <input type="checkbox"/> Other	<input type="checkbox"/> To meet standards ()
Modification Schedule:	From December '04 production		

Old part number	New part number	Description	Q'ty	Int	Page	Index	Note
G0521025	G0761025	Right Duplex Guide Rail	1→1	X/O	11	24	
G0521026	G0761026	Left Duplex Guide Rail	1→1	X/O	11	26	
G0521211	G0761211	Engine Board Bracket	1→1	X/O	23	13	
G0521224	G0761221	PSU Bracket	1→1	X/O	25	16	
G0521225	G0761224	PSU Bracket – 230V	1→1	X/O	25	16	
G0521241	G0761241	Controller Board Bracket	1→1	X/O	23	9	
G0521218	G0761216	Engine Board Cover	1→1	O/O	23	20	
G0523301	G0763301	Support Stay - Bypass	1→1	O/O	13	25	

Change/Reason: Parts standardization with the K-P2.

Note: These parts use non-toxic chromium.